

HIGH PERFORMANCE GRINDERS FOR INDUSTRIAL APPLICATIONS



Automatic Grinder AW G 160 / U 200
Mixer Automatic Grinder MAW G 160 / U 200
Automatic Grinder AW K 280



K+W WETTER



“All K+G WETTER machines have one thing in common: they are stable, indestructible and therefore of enduring quality! Thanks to these qualities, K+G WETTER machines are unmatched in their price/performance ratio!”

Andreas Wetter
Managing Director of K + G Wetter GmbH

THE RIGHT SOLUTION FOR EVERY REQUIREMENT

Page 5

3 CLEAR ARGUMENTS FOR YOUR SUCCESS

Page 6

AUTOMATIC GRINDER AW G 160 / U 200

Universally usable for both
fresh and frozen product

Page 10

MIXER AUTOMATIC GRINDER MAW G 160 / U 200

Thoroughly mixed and perfectly ground

Page 14

INDUSTRIAL GRINDER AW K 280 The all-rounder

Page 16



THE RIGHT SOLUTION FOR EVERY REQUIREMENT

K+G WETTER high performance grinders
for industrial applications

K+G Wetter offers automatic grinders for industrial applications in sizes G 160, U 200 and K 280 mm and mixer automatic grinders in sizes G 160 and U 200. We can supply you with the appropriate machine for any throughput.

Our high performance grinders deliver what they promise – whatever the size. With consistent results for all raw materials. Because only the best machines deliver the best products. Hygiene, safety and efficiency are our top priority.

THE MACHINE QUALITY

- Heavy, stable and robust design
- High production capacities thanks to high performance
- No degradation in performance under continuous operation
- Quiet operation
- Functional and easy to operate
- Low maintenance costs
- Easy to maintain and service
- Exemplary compliance with occupational safety and hygiene requirements
- Automatic self-diagnostics (with AW K 280)
- Long cutting set service life

THE PRODUCT QUALITY

- Clear and clean cut
- No crushing of fat and meat particles
- Lighter consistency for the ground material
- Preservation of the processed quality because there is only a very slight rise in temperature
- Fast and homogeneous mixing of the raw materials using K+G WETTER mixer grinders
- Almost constant throughput independent of the perforation of the hole plates

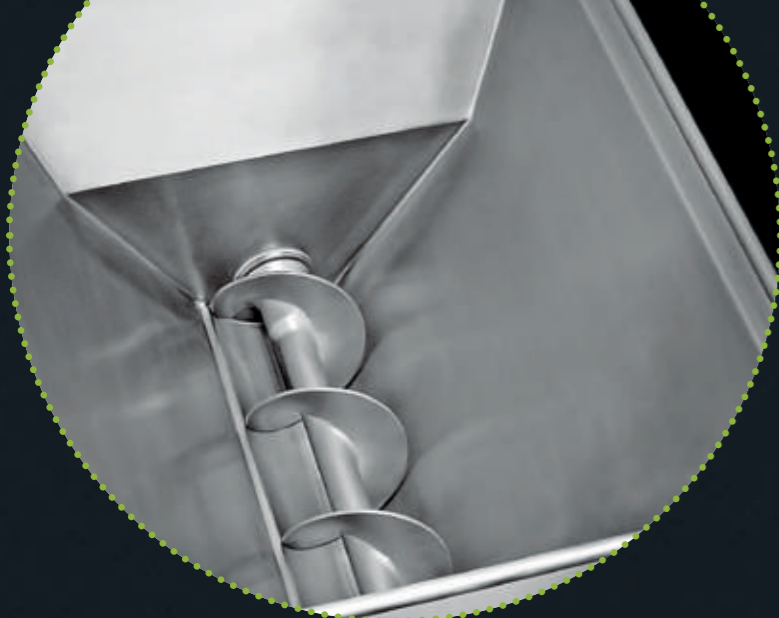

Optimum hygiene and cleaning characteristics

All-round cleanly polished surfaces and weld seams with large corner radii facilitate time-saving and reliable cleaning.

Laser fill level monitoring of the meat grinder hopper*

Complete emptying and overfilling are reliably prevented, thereby extending the service life of the cutting set.



Membrane keyboard offers operating convenience

The membrane keyboard, which is integrated into the machine body, facilitates trouble-free and convenient machine operation. All functions are clearly laid out.



3 CLEAR ARGUMENTS FOR YOUR SUCCESS

Our solutions leverage our know-how – adding value for you



On all K+G Wetter high-performance grinders the feeder worm and meat worm are driven independently of each other. In the hopper floor a feeder worm conveys the process material to the meat worm. This compresses the material in the worm housing and feeds it into the cutting set at the necessary pressure.

The cleaning chamber

The daily cleaning routine ensures the highest possible standard of safety.

- The process material is transported without any additional stress.
- Hardly perceptible increase in temperature.
- The result: A particularly light consistency of the end products.
- Special cutting set and special speed with reduced RPM for heavier materials such as frozen meat.

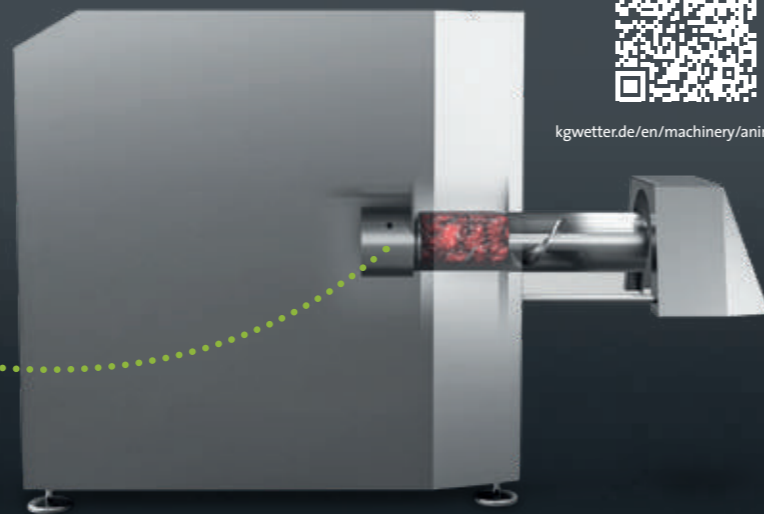
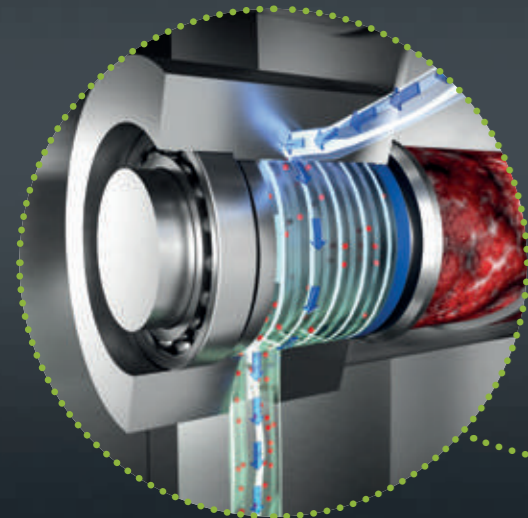

The cleaning chamber easily explained



kgwetter.de/en/machinery/animations

1 WELL THOUGHT-OUT DETAILS

All K+G Wetter machines fulfil the highest hygiene and safety requirements pursuant to the EC Machinery Directive. Cleaning and disinfection of the surfaces, together with the internal drive and bearing areas, is fast and straightforward.

BAYONET LOCK NUT

The cutting set can be secured with a bayonet lock nut which allows it to be rapidly fitted and removed. This proven locking technology protects the thread on the cutting set housing and saves valuable time. Downtimes are reduced and production times increased.

EASY CLEANING WITH A SYSTEM

All components of K+G Wetter machines are extremely easy to access. This is especially beneficial when it comes to intermediate cleaning for a product change.

CERTIFIED HYGIENE

Quality – black on white: Machine safety and hygiene have been externally certified.

HIGH-EFFICIENCY SORTING DEVICE*

- Significant improvement in product quality: Removal of gristle, sinews and hard particles
- Simply designed: Standard cutting set components supplemented with a sorting knife.
- Simple to operate: Hard particles are discharged to the side, the sorting result is immediately visible and adjustable
- Simple to clean: Fit/remove in seconds without using tools.

THE CLEANING CHAMBER GUARANTEES

THE HIGHEST DEGREE OF HYGIENE AND SAFETY

Should low viscosity material penetrate through the worm gear drive seals and flow towards the machine body, this collects in the cleaning chamber and is flushed out when the cleaning program runs.

* Option

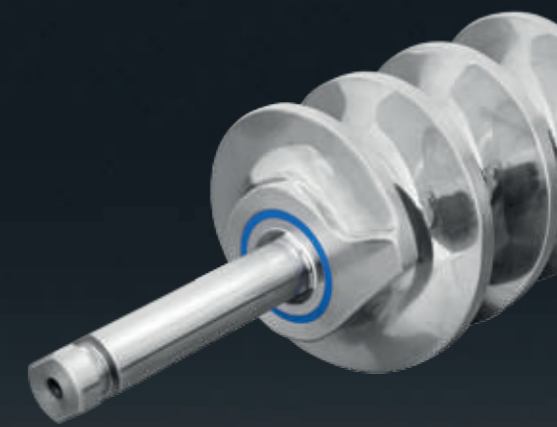

NEW!

Innovative cutter pin

- highly durable connection
- special seal made of particularly durable material
- quick, easy and inexpensive replacement of the cutter pin in case of wear using standard tools
- time-saving and hygienically reliable cleaning thanks to the particularly smooth surface finish
- standard on all grinders and mixer grinders

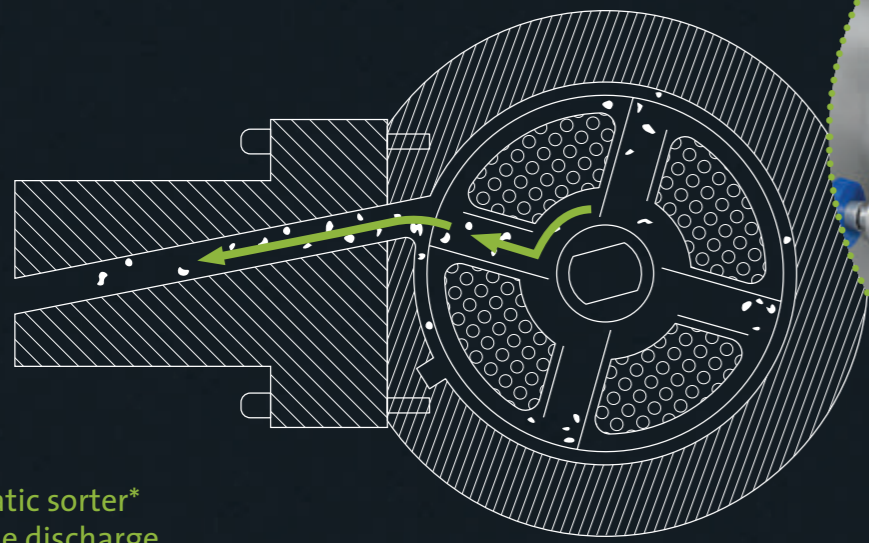

Pneumatic sorter* with side discharge

for even more reproducible sorting results. Standard perforated disks in combination with special sorting knives ensure the largest possible product throughput and significantly better sorting results than conventional systems.

2 UNBEATABLY EFFICIENT

Our high performance grinders are controlled using a smooth, highly durable membrane keyboard that facilitates easy and particularly hygienic cleaning. It offers press-button, highly intuitive control of the machine. The sophisticated technical details ensure particularly high performance and process reliability.

- The electric controller is incorporated into the machine base, where it is well protected.
- Large openings facilitate easy access for care, maintenance and servicing.
- Solid and robust design for an exceptionally long service life.

DELAYED START-UP OF THE MEAT WORM

Initially, only the feeder worm runs and conveys material to the meat worm. Only then does this start turning to convey the material to the cutting set. The cutting set therefore never runs dry and wear is minimised – for significantly longer cutting set service life and a hardly perceptible increase in temperature.

EFFICIENT MATERIAL TRANSPORT

The meat worm drive has two speeds. It is therefore able to collect the source material from the transfer area and feed it into the cutting set without any backlogs or unwanted temperature rises.

TENSIONING DEVICE FOR THE PRE-CUTTER FROM A GRINDER SIZE OF 160 MM

The tensioning device for the pre-cutter mechanically fixes the pre-cutter using a support mounted on the cutting set housing. This significantly reduces the pressure on the cutting set. It offers a longer cutting set service life and a cleaner and clearer cutting pattern.

* Option



The sorting device easily explained



kgwetter.de/en/machinery/animations

NEW! ClearCut – clean cutting and perfect sorting

- available from a cutting set diameter of 114 mm
- optimises the cutting pattern thanks to the new cutting geometry
- reliably sorts out unwanted hard particles such as cartilage, small bone parts or tendons and separates them selectively
- guarantees permanently good results thanks to a long service life
- only the standard knife in the cutting set is exchanged for a sorting knife, a special cutting set is unnecessary
- very good red-white-distribution

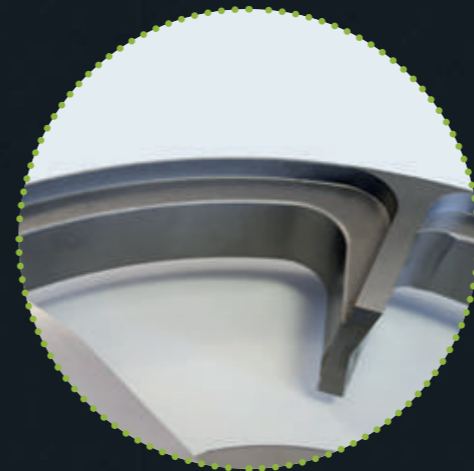

Cleaning trolley

All of the required parts neatly arranged and within easy reach

3 LIMITLESS FLEXIBILITY

LOADING DEVICE

High performance grinders can optionally be loaded quickly and safely using a hydraulic loading device or, alternatively, a hoist loader. The meat trolley is guided precisely during the lifting process and is only tipped when it is fully over the hopper. Depending upon the application, feed conveyors (belt loading), loading devices for large containers or worm conveyors may be used. The loading device can be positioned in accordance with the customer's requirements.

CLEANING TROLLEY

A mobile transport and cleaning trolley allows you to place all parts – such as the mixing shaft, worms, lock nut, etc. – on a trolley, for cleaning and transportation purposes.

Tensioning device for the pre-cutter*

With a single flick of the wrist the pre-cutter is quickly and uniformly locked in-place without using tools – the tensioning device for the pre-cutter can be dismantled for cleaning in just a few seconds

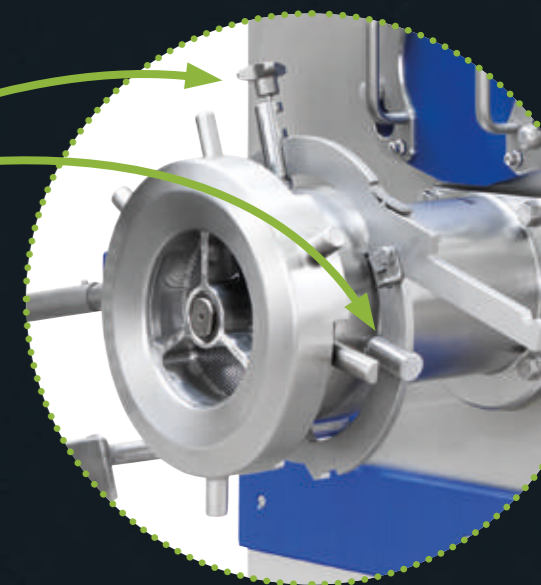

	Mixer Automatic Grinder		Automatic Grinder		
	MAW G 160	MAW U 200	AW G 160	AW U 200	AW K 280
Hole plate ø mm	160	200	160	200	280
Hopper or mixing trough capacity, approx. l	530	530	360	360	575
Max. fresh meat production output in kg/h	8,000	12,000	8,000	12,000	22,000
Max. shredded frozen meat production output in kg/h	-	-	1,500* max -18°C	2,500* max -18°C	16,000* max -21°C
Frozen meat in a block kg/h	-	-	-	-	4,000 - 8,000 max -21°C
Max. mixing capacity kg	350	350	-	-	-
Meat worm drive power kW	17.5/ 30	30/48	17.5/30	30/48	65/88 78/105**
Feeder worm drive power kW	4.7/6	4.7/6	1.3/1.8 1.3/2/2.4*	1.3/1.8 1.3/2/2.4*	16
Sound pressure level under no load dBA	71	70	68	70	83
Loading	Hoist	Hoist	Hoist, hydraulic	Hoist, hydraulic	Hoist, belt, box pallets

* Fresh and frozen meat version / ** reinforced version

AUTOMATIC GRINDER G 160 / U 200

Universally usable
for both fresh and frozen

The Automatic Grinder G 160 / U 200 G 160 / U 200 is our ideal solution for optimum product processing at medium and large enterprises in particular. Reliable, as are all high-performance grinders from K+G Wetter, it ensures safe and smooth production processes. It is flexible in use and delivers top quality product results.

- The process material is transported without any additional stress.
- Hardly perceptible increase in temperature.
- A particularly light consistency of the end products.
- Feeder and meat worms have the same conveying direction and separate drives
- Special cutting set for frozen meat
- Intuitive operation at the touch of a button
- The electric controller is incorporated into the machine base
- Large opening facilitates servicing
- Extremely robust and stable bearing/mounting of the meat worm minimises the axial forces such that there is no contact with the cutting set housing. The housing and cutting set are protected.
- Hydraulic worm ejector (optional) for AW and MAW G 160 and U200 for even faster disassembly.

Can be reliably
cleaned, easy to
maintain

Can be disassembled in just
a few steps. Removal of the
counter bearing facilitates
hygienically reliable cleaning
and visual checking.

DIMENSIONS

Automatic Grinder AW G 160 / U 200
hydraulic loading device

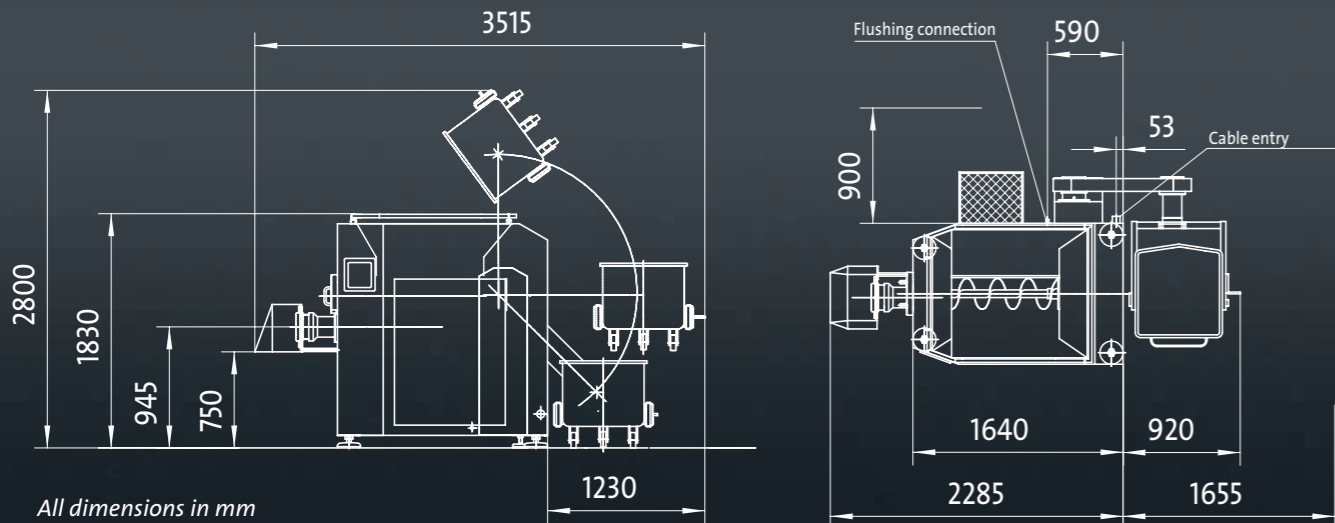

All dimensions in mm





Cleaning platform with solenoid switch

When the cleaning platform is unfolded the grinder stops automatically.



TECHNICAL SPECIFICATIONS AW G 160 / U 200

		AW G 160		AW U 200	
Version		Fresh meat	Fresh and frozen meat	Fresh meat	Fresh and frozen meat
Electrical specifications	Operating voltage (standard)	400V / 50Hz		400V / 50Hz	
	Rated connected load	32.5 kW		52.1 kW	
	Rated current	67 A		93.7 A	
	Incoming supply fuse – customer side	80 A gL/gG		100 A gL/gG	
Rotational speeds	Meat worm	180/360 min ⁻¹	140/280 min ⁻¹	180/360 min ⁻¹	140/280 min ⁻¹
	Feeder worm	10/20 min ⁻¹	5/8/16.5 min ⁻¹	14/28 min ⁻¹	7.5/12/24 min ⁻¹
Grinder processing capacity		Up to 134 kg/min	Fresh meat Up to 103 kg/min Frozen meat Up to 27 kg/min	Up to 200 kg/min	Fresh meat Up to 130 kg/min Frozen meat Up to 40 kg/min
Hopper capacity		360 l		360 l	
Sound power level at no load		Approx. 68 dBA		Approx. 70 dBA	
Weight	Without loading device	1,950 kg		2,030 kg	
	Incl. hydraulic loading device	2,320 kg		2,400 kg	

DIMENSIONS

Automatic Grinder AW G 160 / U 200
Hoist loader

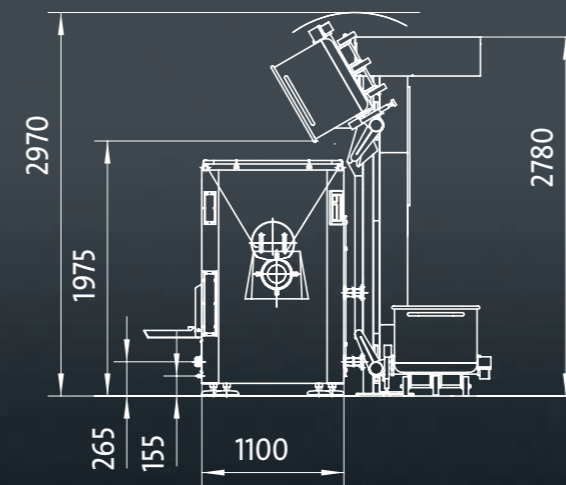

All dimensions in mm

Flushing connection

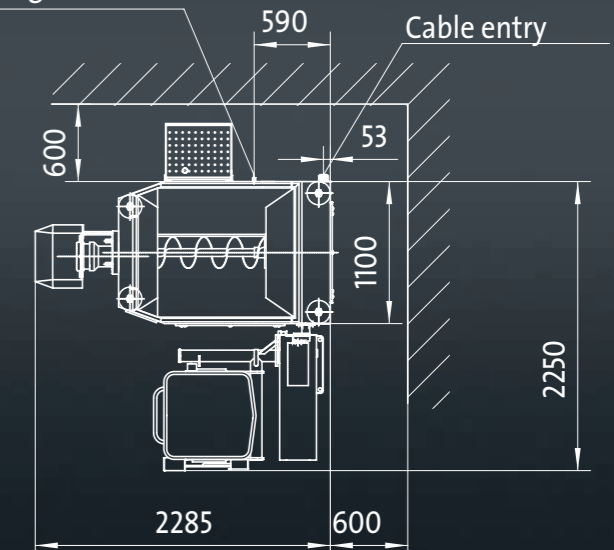

MIXER AUTOMATIC GRINDER MAW G 160 / U 200

Thoroughly mixed and perfectly ground

The mixing function significantly expands the range of applications of the grinders: One machine – two functions. The raw materials are quickly and thoroughly mixed and then cleanly and lightly cut. The unique feature: A mixing shaft with specially formed paddles is mounted in the grinder's hopper above the feeder worm. This ensures an intensive, but particularly gentle mixing process.

DOUBLY STRONG: MIXING AND GRINDING COM- BINED IN A SINGLE MACHINE

- During the mixing process the feeder worm rotates in the opposite direction to normal. A product cycle is therefore created between the mixing shaft and feeder worm, which enhances the mixing process. The mixing speed and time can optionally be shown on the display.
- Once the mixing process is complete the system switches to "grind". The mixing shaft and feeder worm change their direction of rotation. The process material is then conveyed via the meat worm to the cutting set.
- The Mixer Automatic Grinders are equipped with a working platform. The mixing trough is electrically secured by a continuous frame with contact switches.
- Reproducible mixing results are ensured by the pre-selectable mixing time and corresponding shut-off.



Intensive, gentle
mixing process

The reverse running of the feeder worm means that the material is thoroughly mixed. Residue formation on the hopper base is also prevented in this way.

TECHNICAL SPECIFICATIONS MAW G 160 / U 200

	MAW G 160	MAW U 200	
Electrical specifications	Operating voltage (standard)	400 V / 50 Hz	400 V / 50 Hz
	Rated connected load	36 kW	54.9 kW
	Rated current	72 A	99.2 A
	Incoming supply fuse – customer side	80 A gL/gG	100 A gL/gG
Rotational speeds	Meat worm	180/360 min ⁻¹	180/360 min ⁻¹
	Feeder worm	10/20 min ⁻¹	14/28 min ⁻¹
	Mixing shaft	5/10 min ⁻¹	5/10 min ⁻¹
Grinder processing capacity	Up to 134 kg/min	Up to 200 kg/min	
Hopper capacity	530 l	530 l	
Mixing capacity	350 kg	350 kg	
Sound power level at no load	Approx. 71 dB _A	Approx. 70 dB _A	
Weight	Without loading device	2,200 kg	2,280 kg
	Hoist loader	350 kg	350 kg

DIMENSIONS

Mixer Automatic Grinder
MAW G 160 / U 200

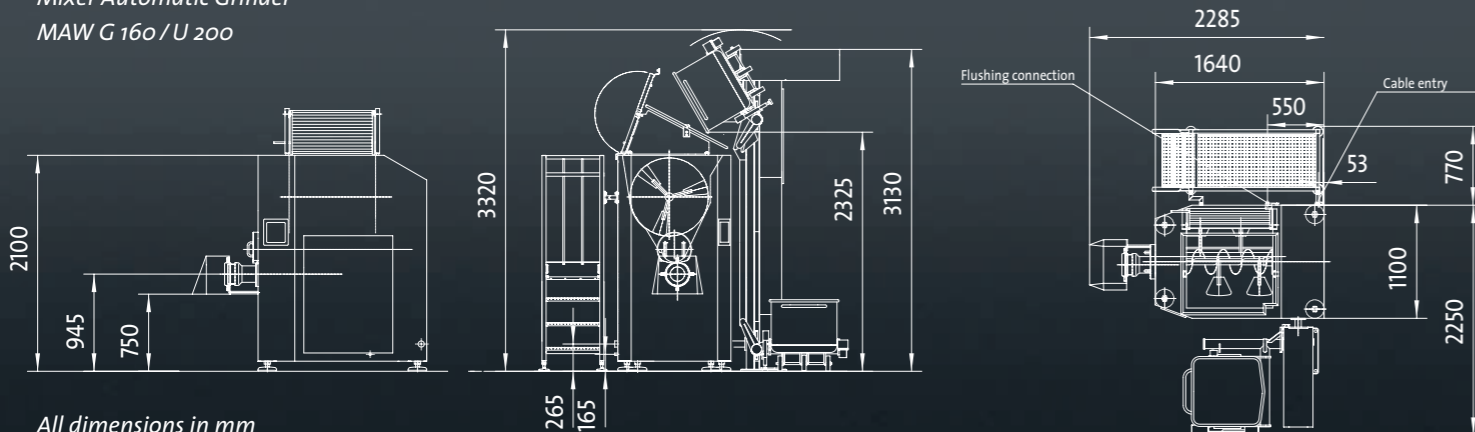

All dimensions in mm

INDUSTRIAL GRINDER AW K 280

The all-rounder

The massive Industrial Grinder K 280 Type 435 is a high-performance machine that is optimally suited to continuous operation. Thanks to its immense strength and feeder worm made of special cast iron with skinning edge, the Industrial Grinder K 280 can cut frozen blocks at temperatures as low as minus 22°C, rather than crushing them – and this with a minimum temperature rise of 1 to max. 2°C. The result is a clean and clear cut with no smearing.

The automatic grinder can be loaded either using a hoist loader or a conveyor belt. A metal detector for the conveyor belt is available as an option. A special feature is the innovative cleaning device that eliminates the need for detaching the feeder worm. As with all of the industrial grinders a pneumatic sorting device is available as an option.

Everything to make working with this high performance grinder simple, quick and safe is included in the standard scope of delivery.

- Bayonet coupling nut for quick installation of the cutting set
- A special frozen meat cutting set
- Leak protection for the worm housing
- Switch frame above the grinder hopper
- Cleaning platform with non-slip steps and high railing
- Height-adjustable cleaning and transport trolley
- Complete hopper emptying



Cleaning with a system

It is not necessary to detach the feeder worm for cleaning, it only needs to be pulled forwards.

DIMENSIONS

Industrial Grinder AW K 280, hoist loader

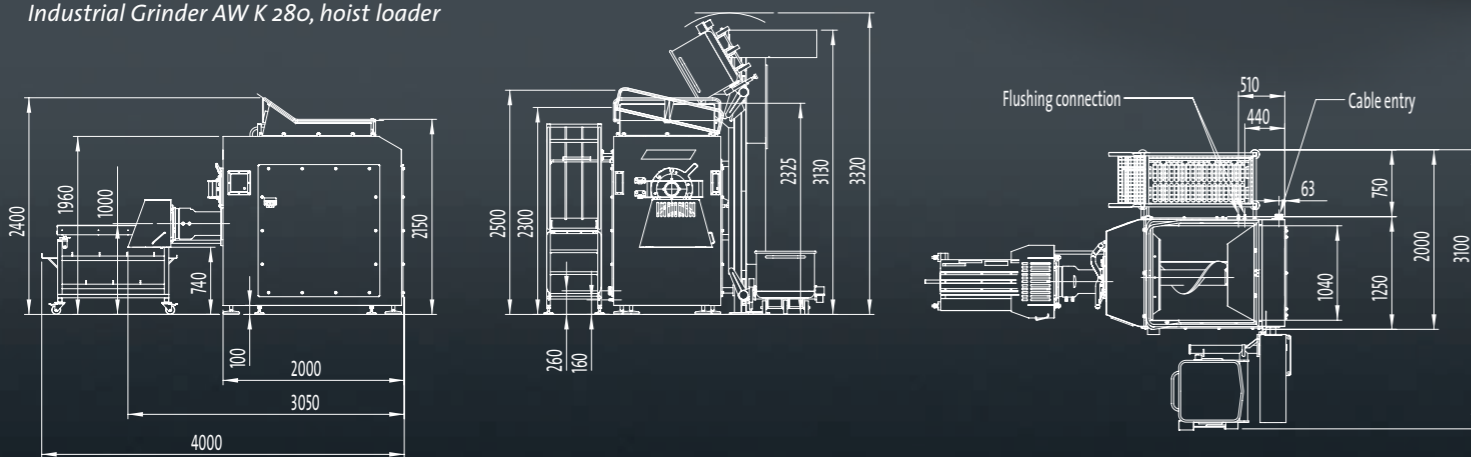

All dimensions in mm

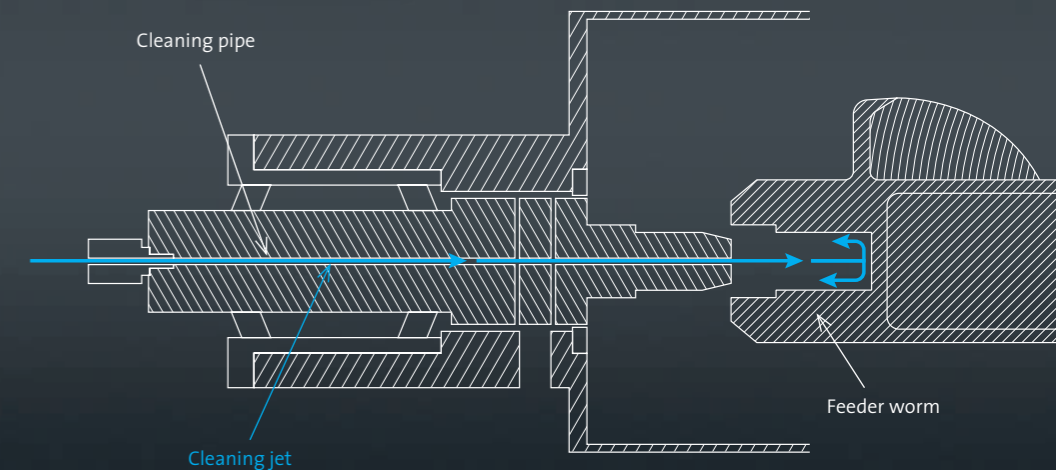

Cutting set housing
Solid stainless steel design

Drainage channel
for hygienically
reliable cleaning

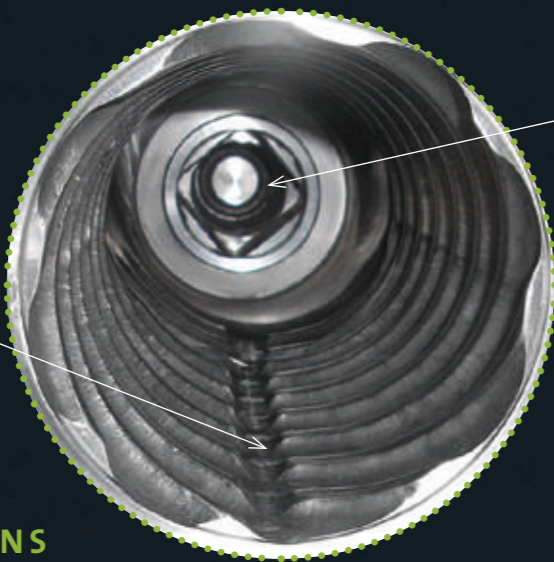

Robust mountings
for the worm bearings

TECHNICAL SPECIFICATIONS AW K 280

Type		435	
Electrical specifications	Operating voltage (standard)	400 V / 50 Hz	
	Rated connected load	104.8 kW	121.8 kW
	Rated current	196 A	223 A
	Incoming supply fuse – customer side	200 A gL/gG	250 A gL/gG
Rotational speeds	Meat worm	105/210 min ⁻¹	
	Feeder worm	5...25 min ⁻¹	
Processing	Grinding frozen meat blocks	3,500...8,000 kg/h	
	Grinding pre-ground frozen meat	Up to 16,000 kg/h	
	Grinding fresh meat	Up to 22,000 kg/h	
Hopper capacity		635 l	
Sound power level at no load		Approx. 83 dBa	
Weight	Without loading device	3,940 kg	
	Hoist loader	330 kg	
	Cleaning platform	90 kg	

DIMENSIONS

Industrial Grinder AW K 280, conveyor loader

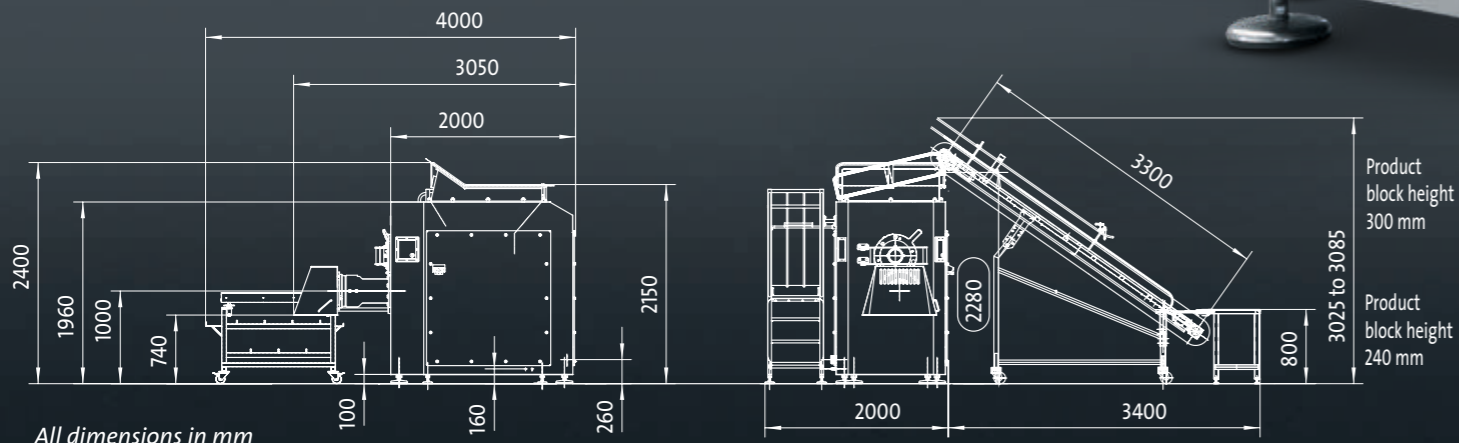

All dimensions in mm



MADE IN GERMANY

A GOOD DECISION

Quality pays off

You earn your money with our machines. We are aware of this responsibility – and this can be seen in our high-quality solutions. Well thought-out down to the last detail, they will ensure efficient processes and a high degree of security at your company for decades to come. You can be assured that you have made the right choice.

DROP BY

We would be delighted to show you where and how our cutters, grinders and mixers for trade and industry are made. On a tour of our production facilities in the beautiful State of Hesse you will gain a sense of what has always driven us at K+G Wetter: The passion of always setting further standards with our ideas. For pure enjoyment – and your success. Worldwide.

Come and see for yourself. We look forward to meeting you!

ALL-ROUND SHARPENING SERVICE

Directly from the professionals

If the performance of your cutting tool fades after intensive use we will restore its sharpness in the shortest possible time – safe transport included. More information can be found at: kgwetter.de/schleifservice

K+G WETTER

K+G WETTER GmbH
Goldbergstraße 21
35216 Biedenkopf-Breidenstein

Tel. +49 (0) 64 61 / 98 40 - 0
Fax +49 (0) 64 61 / 98 40 - 25

info@kgwetter.de
www.kgwetter.de